

B 09902

BUNK BED

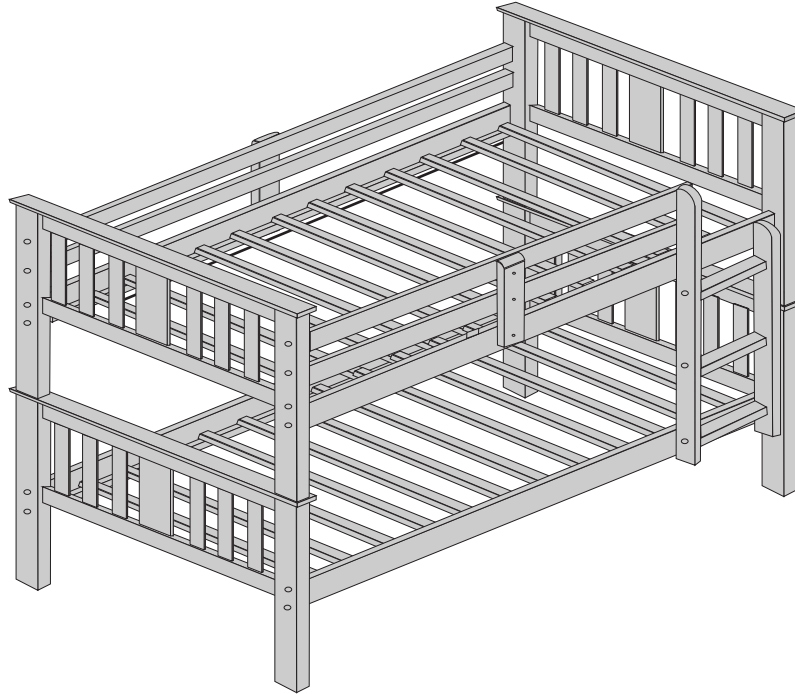

IMPORTANT:







READ CAREFULLY - RETAIN FOR FUTURE REFERENCE

PLEASE READ BEFORE YOU CONTINUE FURTHER

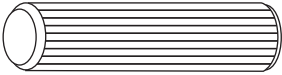
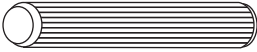
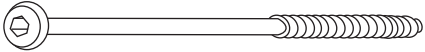
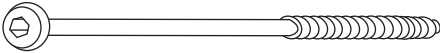
CARE AND MAINTENANCE

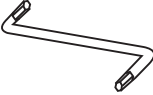
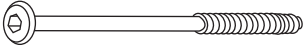
- THE UPPER BED OF THE BUNK IS NOT SUITABLE FOR CHILDREN UNDER SIX YEARS OF AGE DUE TO THE RISK OF INJURY FROM FALLING.

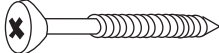
- Strangulation Hazard- never attach or hang items to any part of the bunk bed: for example, hooks, belts, cords, harness ECT.
- The recommended mattress size for this bunk bed is 6'3" x 3' x 6" (1900mmx900mmx160mm).
- The maximum mattress thickness is 6".
- The maximum mattress height is clearly marked on the bunk and **MUST NOT BE EXCEEDED.**
- Children can become trapped between the bed and the wall. To avoid risk of serious injury the distance between the top safety barrier and the wall shall not exceed 75mm or shall be more than 230mm.
- The bunk bed should not be used if any structural part is broken or missing.
- Assemble on a soft clean surface.
- Do not use any tools other than those shown.
- Any spanners or Allen Keys required are included with the fittings kit.
- Do not for any reason use a power tool to assemble this product, Its use will invalidate any claim you may have and could make this product unsafe.
- Assembly fittings should always be tightened properly and care should be taken that no fittings are loose.
- Depending on the amount of use this product receive it may be necessary to tighten up the fittings from time to time. This is completely normal for any at pack furniture. **DO NOT OVERTIGHTEN FIXINGS.**
- Two persons required to assemble this product.
- For cleaning you may use a damp cloth (not wet).
- This bunk is manufactured to conform to **BSEN747-1:2012+A1:2015**
- To clean, wipe a sponge and warm soapy water. Do not use solvent based cleaners or detergents as they can bleach or damage the product.

PART NUMBER	QUANTITY	IMAGE	DIMENSIONS
A	04		15 x 90 mm
B	32		10 x 40 mm
C	06		7 x 100 mm
D	08		1/4 x 110 mm
E	08		ELLIPTICAL 1/4
F	01		
G	12		7 x 50 mm
H	70		4 x 35 mm CC
I	02		GLUEE
K	12		5 x 60 mm FL
L	02		SPACE BLOCK
M	22		



*Please check contents and read the instructions before commencing assembly.
 *Assemble this product following the enclosed instructions carefully.
 *Please take care to avoid damaging parts during assembly.
 *Please assemble on a clean soft surface to avoid damage.

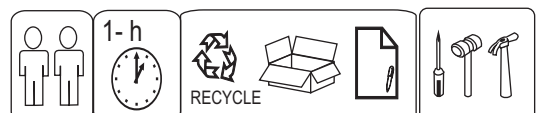

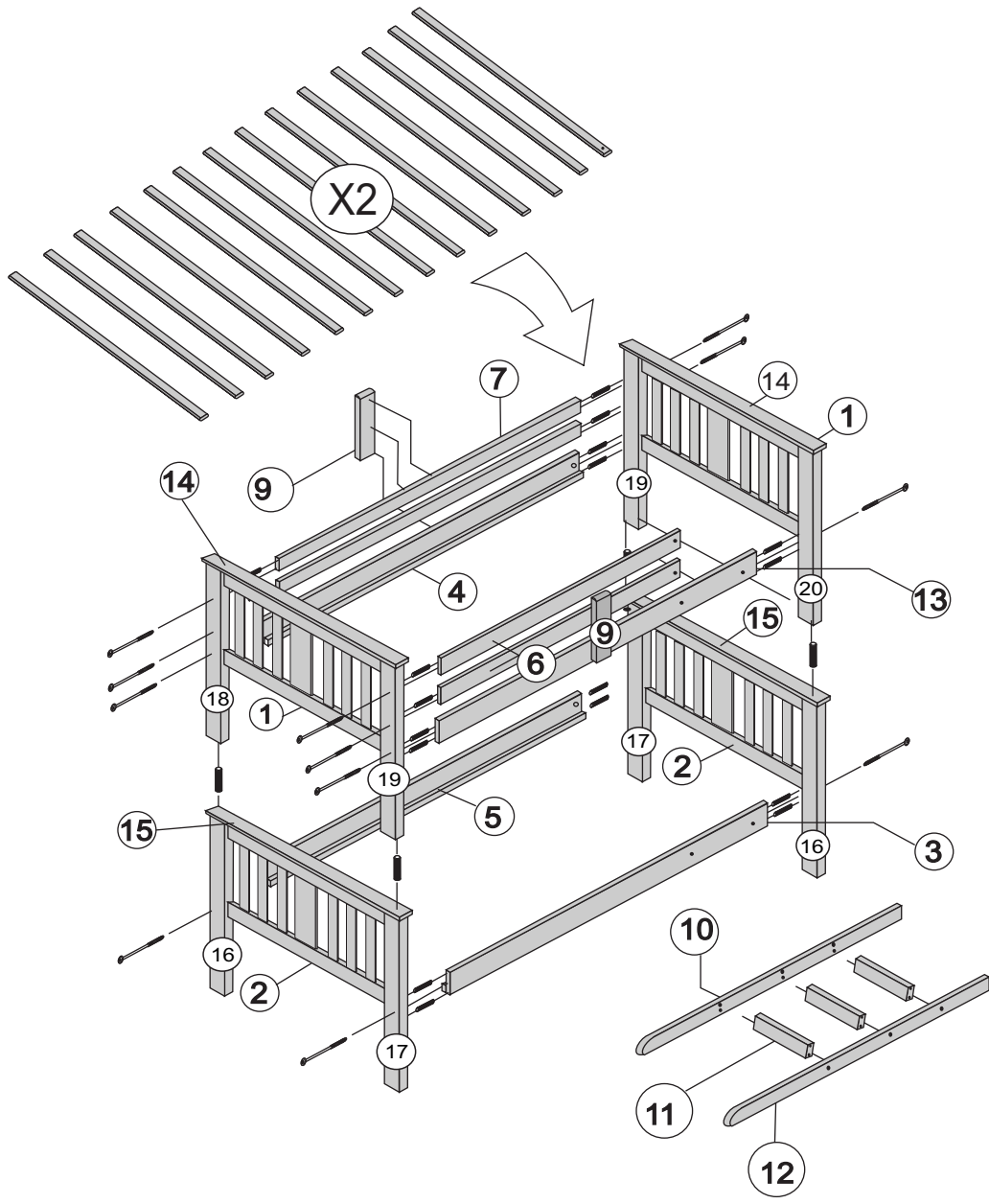

Step 1

Bx22
10x40

This block contains the step number 'Step 1', a quantity 'Bx22' and dimensions '10x40' for the slats, and three icons: a person, a screwdriver, and a mallet.

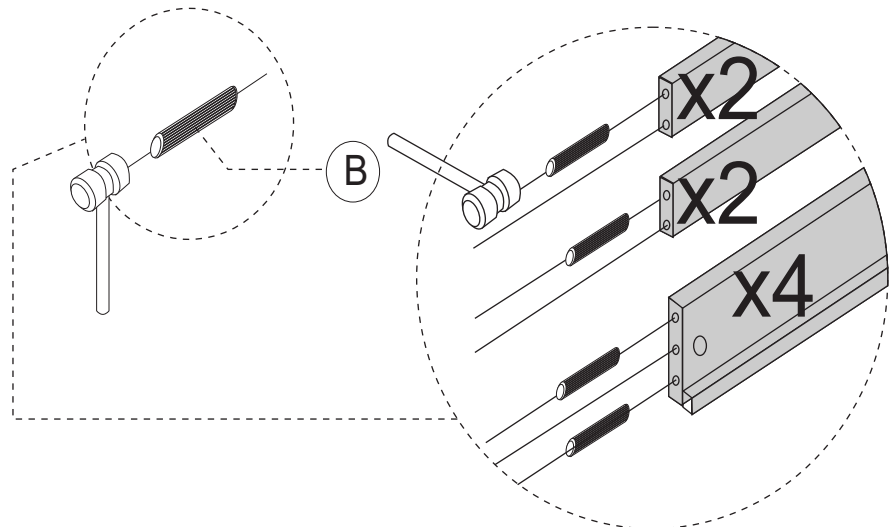

Step 2

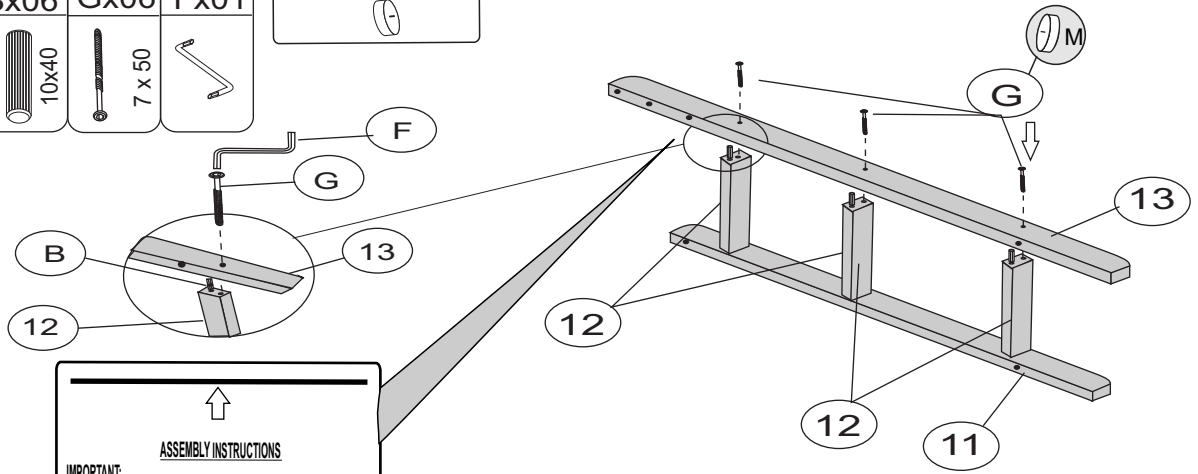
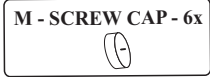
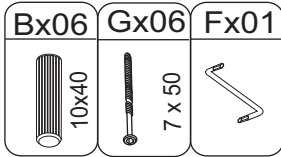

ASSEMBLY INSTRUCTIONS

IMPORTANT:
C - For security reasons the maximum height of the upper mattress must not exceed the mark located on the upper post.

Step 3

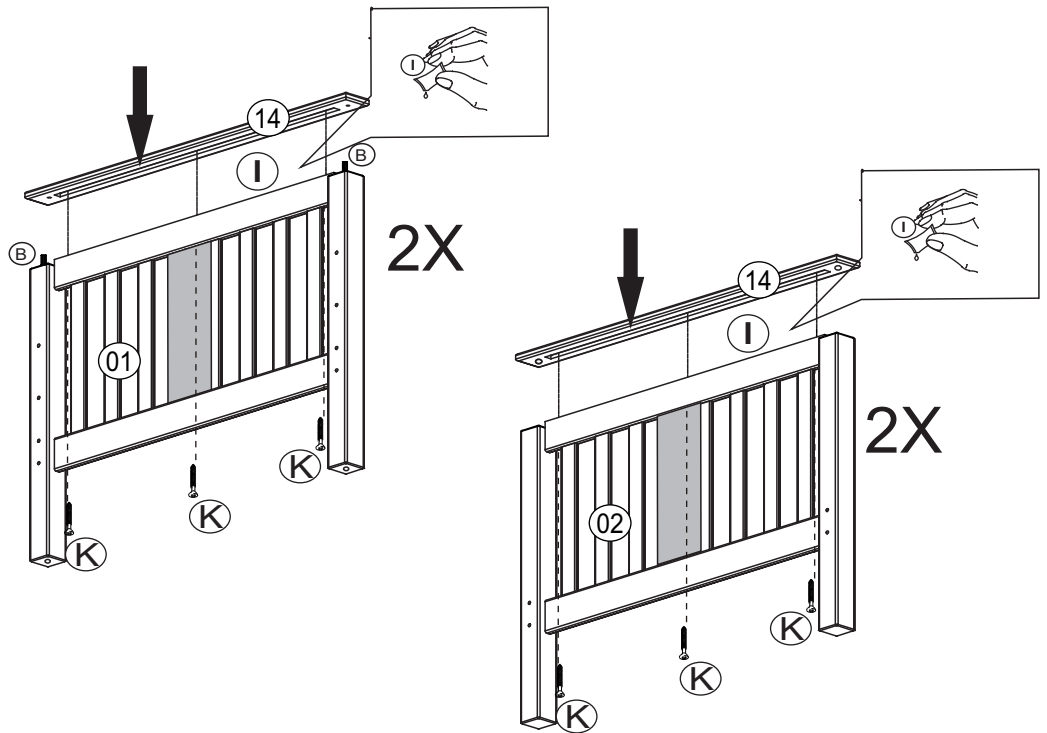
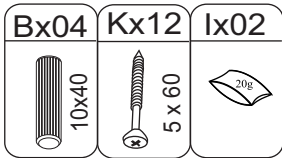

Step 4

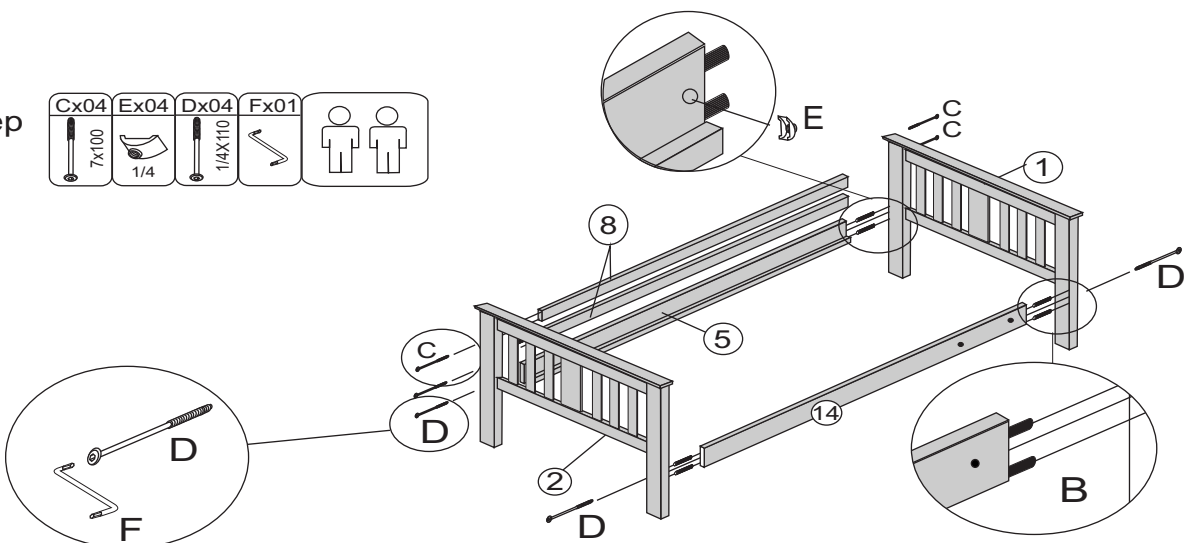
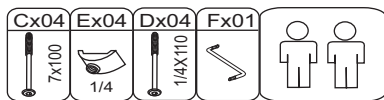

Step
5

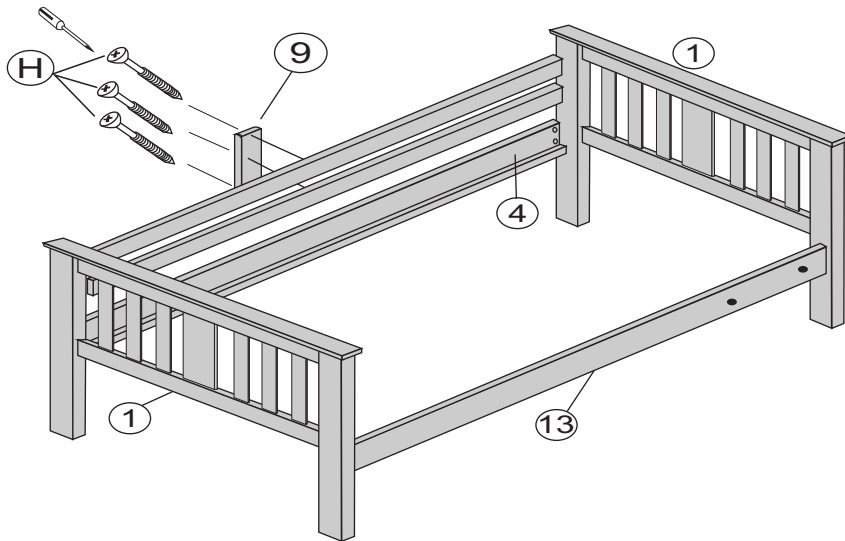
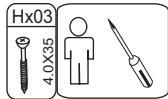

Step
6

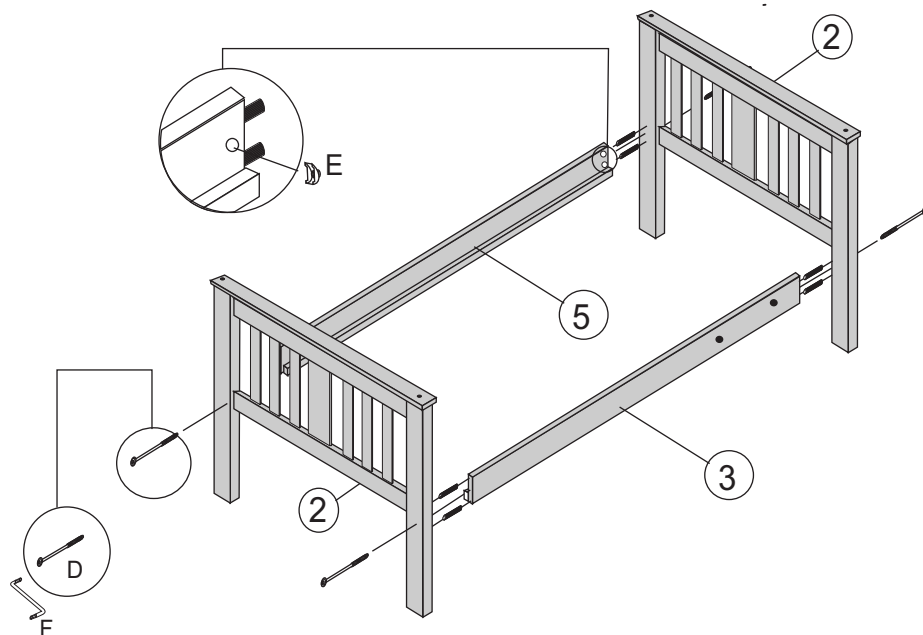
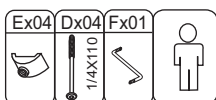

Step
7

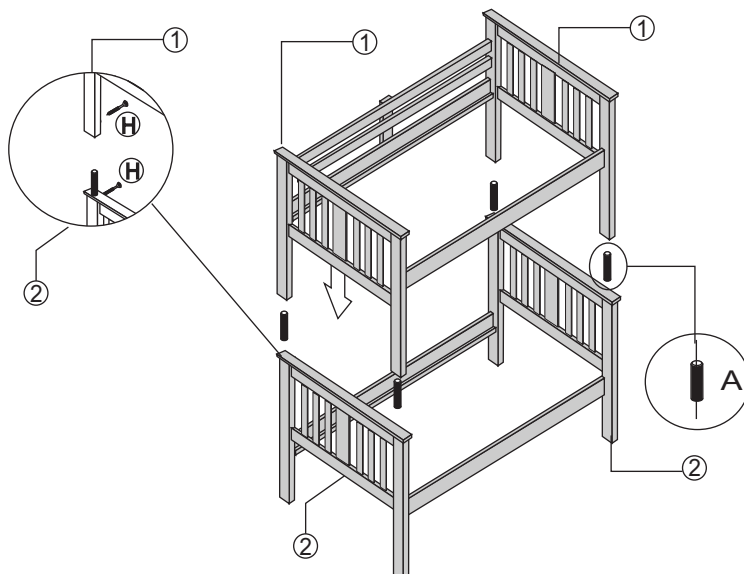
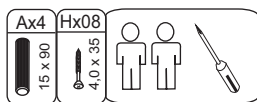

Step
8

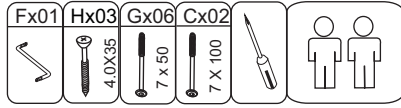

1° Step

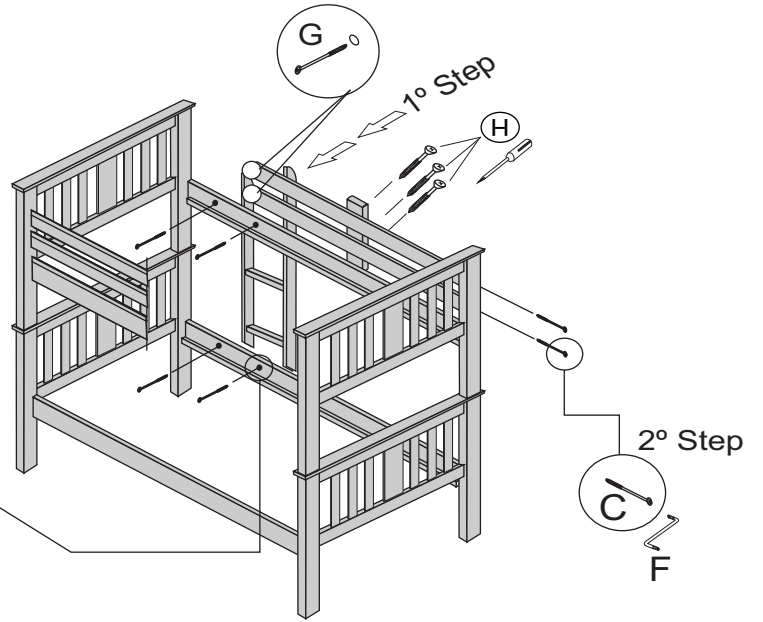

Step
9

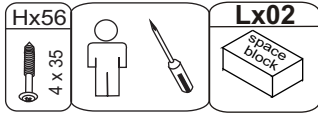

X2

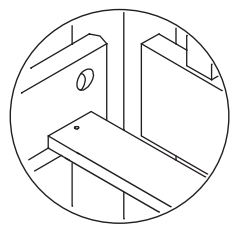
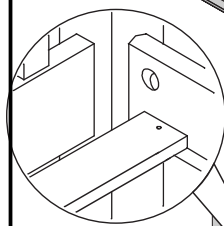
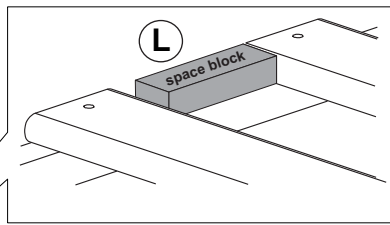
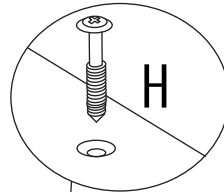

Important – the position of both the first and last slats must be against the post”

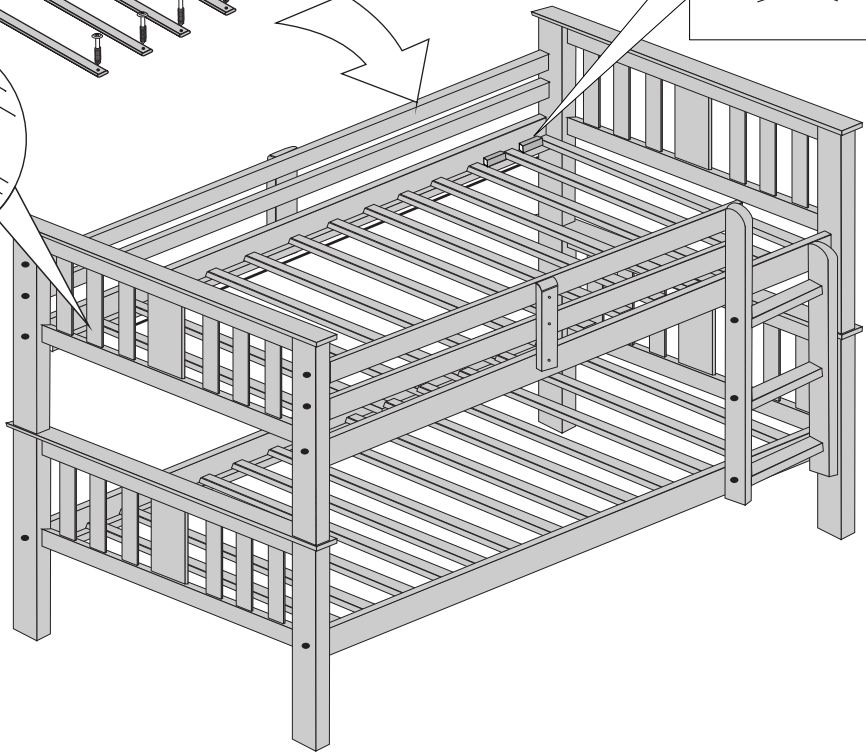

M - SCREW CAP-16x

